



SPARE PARTS CATALOGUE
SFP9 OR PB MATCH PISTOL
IDENT.-NO. 255835

Heckler & Koch is a leading firearms manufacturer of global proportions, yet remains firmly rooted in Germany. The company has been a dependable partner to security forces, police and special forces of NATO and its associated states for over 70 years.

Heckler & Koch stands for superlative quality and innovative products. Heckler & Koch is also the only small arm supplier with a comprehensive product portfolio. Its range includes pistols, submachine guns, assault rifles, designated marksman rifles, training systems and 40 mm systems.

Walter Trading S.r.o., 10004749
QUALITY. INNOVATION. SERVICE. SAFETY.

Table of contents

▶ Using this spare parts catalogue	4
Purpose of this spare parts catalogue	4
Target audience for this spare parts catalogue	4
Information in the spare parts catalogue	4
▶ Spare Parts Documentation	6
Assembly groups	6
Slide, compl.	8
Barrel, compl.	12
Frame, compl.	14
Magazine, compl.	18
▶ Cleaning kit	20
▶ Notes	22

Refer to the protection notice under ISO 16016!

Any transfer of the documentation, be it in full or in excerpt, or making content available to third parties, regardless of the form of information, without the written consent of Heckler & Koch GmbH is prohibited and will be prosecuted!

Using this spare parts catalogue

Purpose of this spare parts catalogue

This spare parts catalogue can be used to order individual components and assembly groups for the weapon. Parts and assembly groups can be ordered from Heckler & Koch by indicating the weapon, designation and Ident.-No.







Target audience for this spare parts catalogue

This spare parts catalogue is intended for trained firearms technicians and administrative personnel.

Information in the spare parts catalogue

This spare parts catalogue contains all of the information that is necessary to order individual components and assembly groups for the weapon. The contents of this spare parts catalogue have the following meanings:

INFORMATION	MEANING
Illustration of individual components	The illustration of individual components is an exploded view showing all parts of the weapon that can be ordered.
Item (Item Number)	The Item Number shows the number of the part in the exploded view. If there is a „>“ instead of the Item Number, then the indicated item is an assembly group and includes several parts.
Designation	The designation contains the name of the part. If more than one of a part is present, then the number of parts is shown in brackets after the designation, e.g. (2x).
Optional	These parts can be ordered as an alternative or supplementary to the parts installed in the weapon.

INFORMATION	MEANING
 Ident.-No.	The Ident.-No. (Identification Number) is Heckler & Koch's internal number for identifying products and individual components.
 NATO Stock Number	The NATO Stock Number is an international code for the classification of products and individual components.
 Quantity per 100 weapons	This number indicates the recommended quantity to keep in stock per 100 weapons. The quantity includes both wearing parts and parts which may become lost. This information represents theoretical values based on experience, and may vary in practice.
 Proof firing required	The designation „X“ shows those parts who are proof firing required. Parts who are proof firing required can only orderd as assembly groups from Heckler & Koch.
 Comments	This column may contain additional information.
 Colour	The column contains information about the colour shade for the parts: SW = black / FDE = flat dark earth / GB = green brown similar to RAL8000 / SB = sand brown RAL8031

Walter Trading S.r.l. 1004749



ASSEMBLY GROUPS



SFP9 OR PB MATCH 19 mm x 19 Calibre

ITEM	DESIGNATION	ID	NSN	SP 100		COMMENTS
>	SFP9 OR PB Match Pistol, compl. (Item 1 - 4)	255835		--		
1	Slide, compl.	255836		3	X	Mount for red dot sight / Charging supports: size L
2	Barrel	255718		--	X	
3	Recoil spring, compl.	226359		5		only as recoil spring, compl. available
4	Frame, compl.	255779		--		Back strap & grip shells: size M

Walter Trading S.r.o., 10004749

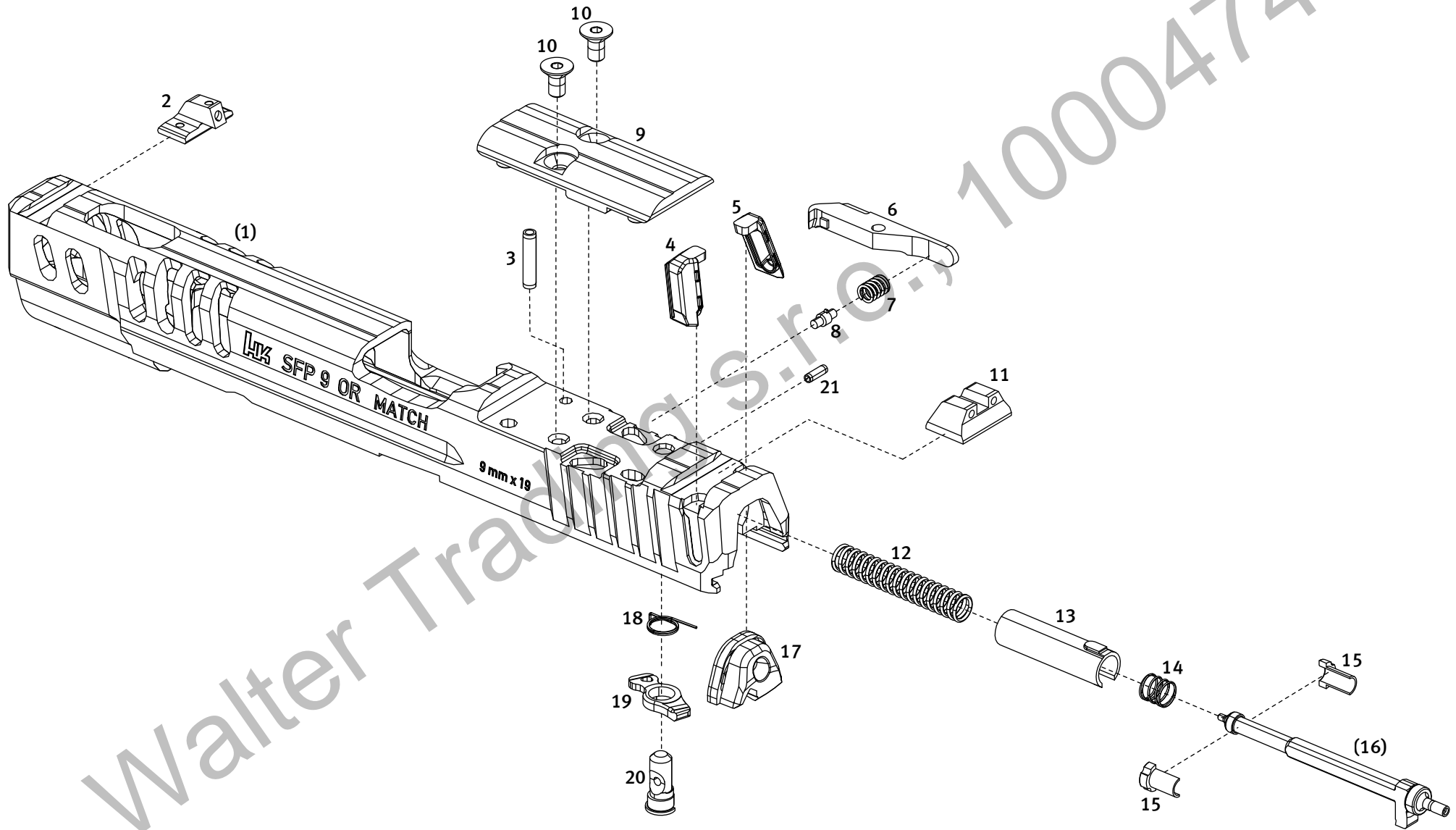

SLIDE, COMPL.



SFP9 OR PB MATCH 19 mm x 19 Calibre

ITEM	DESIGNATION	ID	NSN	SP 100		COMMENTS
>	Slide, compl. (Item 1 - 21)	255836		--	X	Mount for red dot sight / charging supports: size L
1	Slide	--		--	X	Mount for red dot sight. Only as slide, compl. available.
2	Front sight, height 5.9 mm	227711		5		
2.1	Front sight, height 6.1 mm	234327		5		
2.2	Front sight, height 6.3 mm	234328		5		
2.3	Front sight, height 6.5 mm	234329		5		
2.4	Front sight, height 6.7 mm	234386		5		
2.5	Front sight, height 6.9 mm	234387		5		
3	Clamping sleeve for extractor	987455		10		
4	Charging support L, left	239261		5		
5	Charging support L, right	239260		5		
6	Extractor	218314		5		
7	Pressure spring for extractor	218315		5		
8	Rubber plug	209294		5		
9	Cover plate	254258		5		
10	Screw (2x)	255747		20		ISO 10642 M4 x 8 mm / quality class 12.9 / with screw locking / torque 2 Nm
11	Rear sight	223217		5		
>>	Firing pin, compl. (Item 12 - 16)	255775		--		
12	Main spring	239308		5		
13	Support sleeve	260488		5		
14	Pressure spring for firing pin	260487		5		
15	Spring washer (2x)	260489		10		
16	Firing pin	--		--		only as firing pin, compl. available

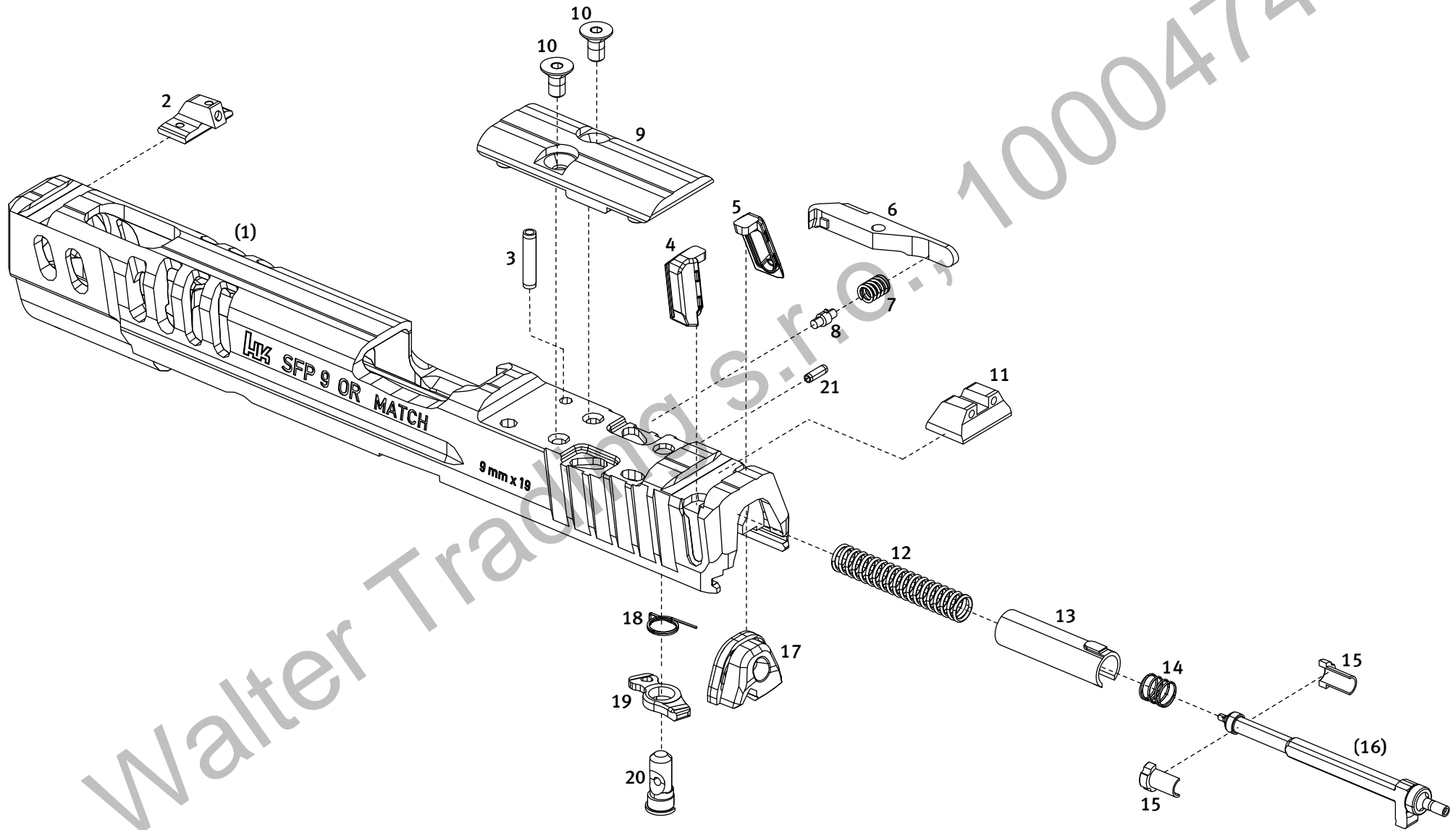

SLIDE, COMPL.



SFP9 OR PB MATCH 19 mm x 19 Calibre

ITEM	DESIGNATION	ID	NSN	SP 100		COMMENTS
17	Slide plate	260504		5		
18	Elbow spring for firing pin safety	260478		5		
19	Firing pin safety	226316		3		
20	Axle for firing pin safety	239863		3		
21	Clamping sleeve for axle	976574		10		

Walter Trading S.r.o., 10004749

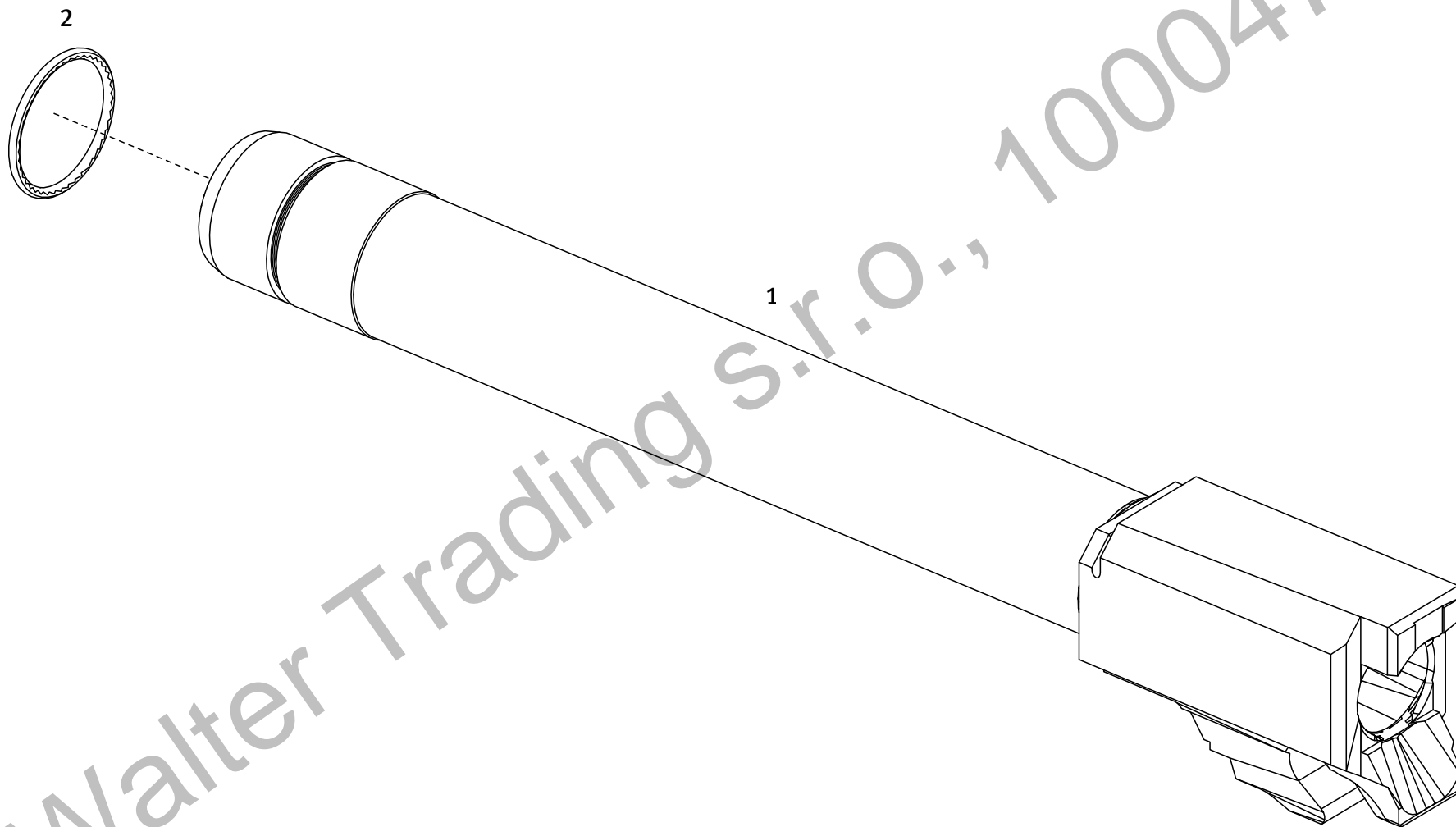

BARREL, COMPL.



SFP9 OR PB MATCH 19 mm x 19 Calibre

ITEM	DESIGNATION	ID	NSN	SP 100		COMMENTS
>	Barrel, compl. (Item 1 - 2)	255718		--	X	
1	Barrel	254153		3	X	
2	O-ring	946312		--		

Walter Trading S.r.o., 10004749

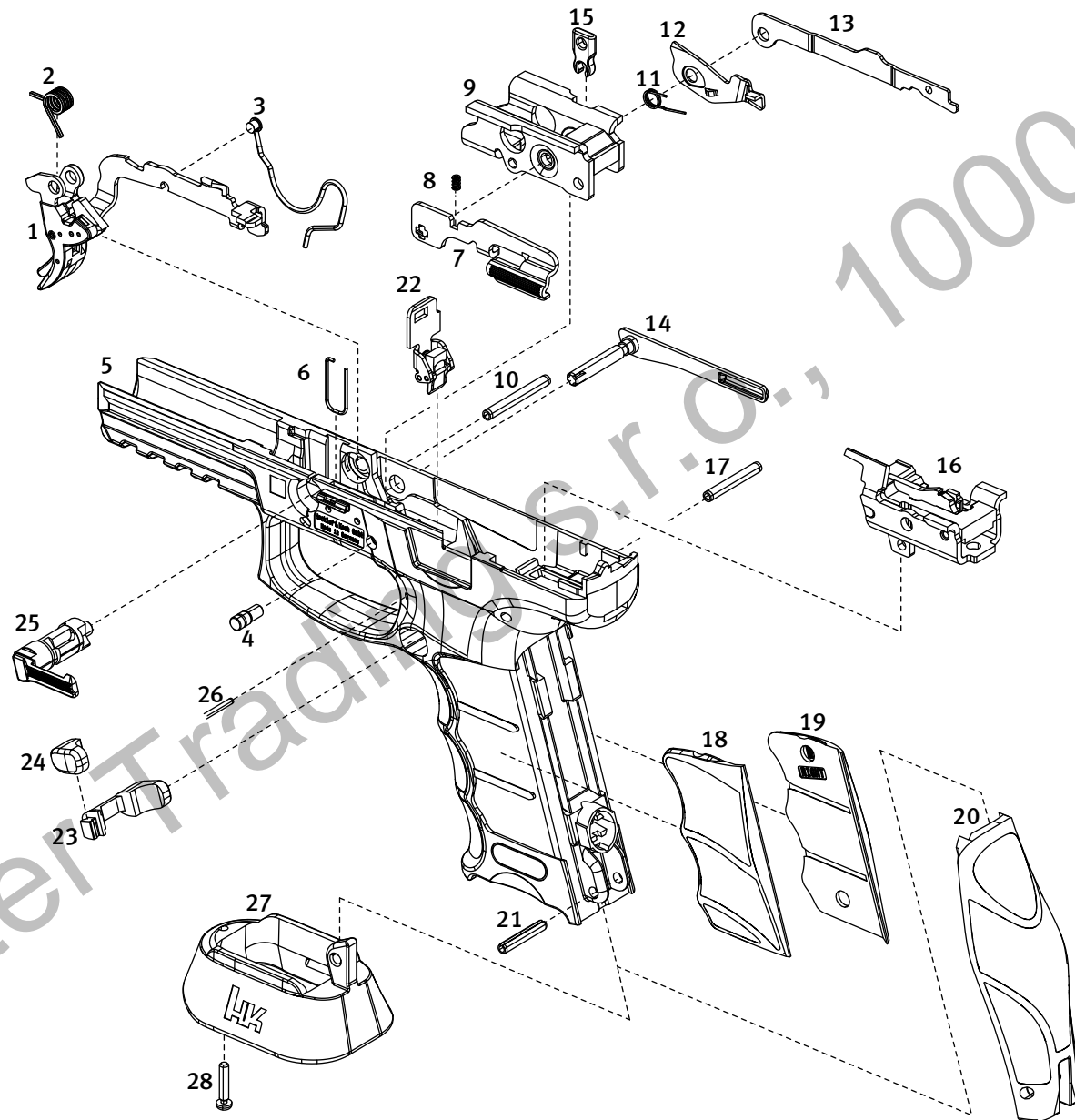

FRAME, COMPL.



SFP9 OR PB MATCH 19 mm x 19 Calibre

ITEM	DESIGNATION	ID	NSN	SP 100		COMMENTS
>	Frame, compl. (Item 1 - 28)	255779		--		Back strap & grip shells: size M
1	Trigger, compl.	257273		5		
2	Elbow spring for trigger	254794		5		
3	Shaped spring for trigger bar, compl.	250852		10		
4	Stop bolt for trigger	260440		5		
5	Frame	254847		--		
6	Stop spring for disassembly lever	260453		10		
7	Slide release, left	260431		5		
8	Pressure spring for slide release	260454		20		
9	Locking block	260501		5		
10	Clamping sleeve for locking block	226312		10		
11	Elbow spring for disassembly safety	260429		10		
12	Disassembly safety	260430		5		
13	Disconnecter	223452		5		
14	Slide release, right	260498		5		
15	Safety clamp	260436		5		
16	Trigger housing, compl.	254297		--		After the trigger housing, compl. has been replaced the clamping sleeve for trigger housing (Pos. 17) must also be repaledced.
17	Clamping sleeve for trigger housing	975715		10		
18	Grip shell M, left	260445		3		
19	Grip shell M, right	260446		3		
20	Back strap M	260444		3		
21	Clamping sleeve for back strap	978170		10		
22	Magazine catch, compl.	250819				

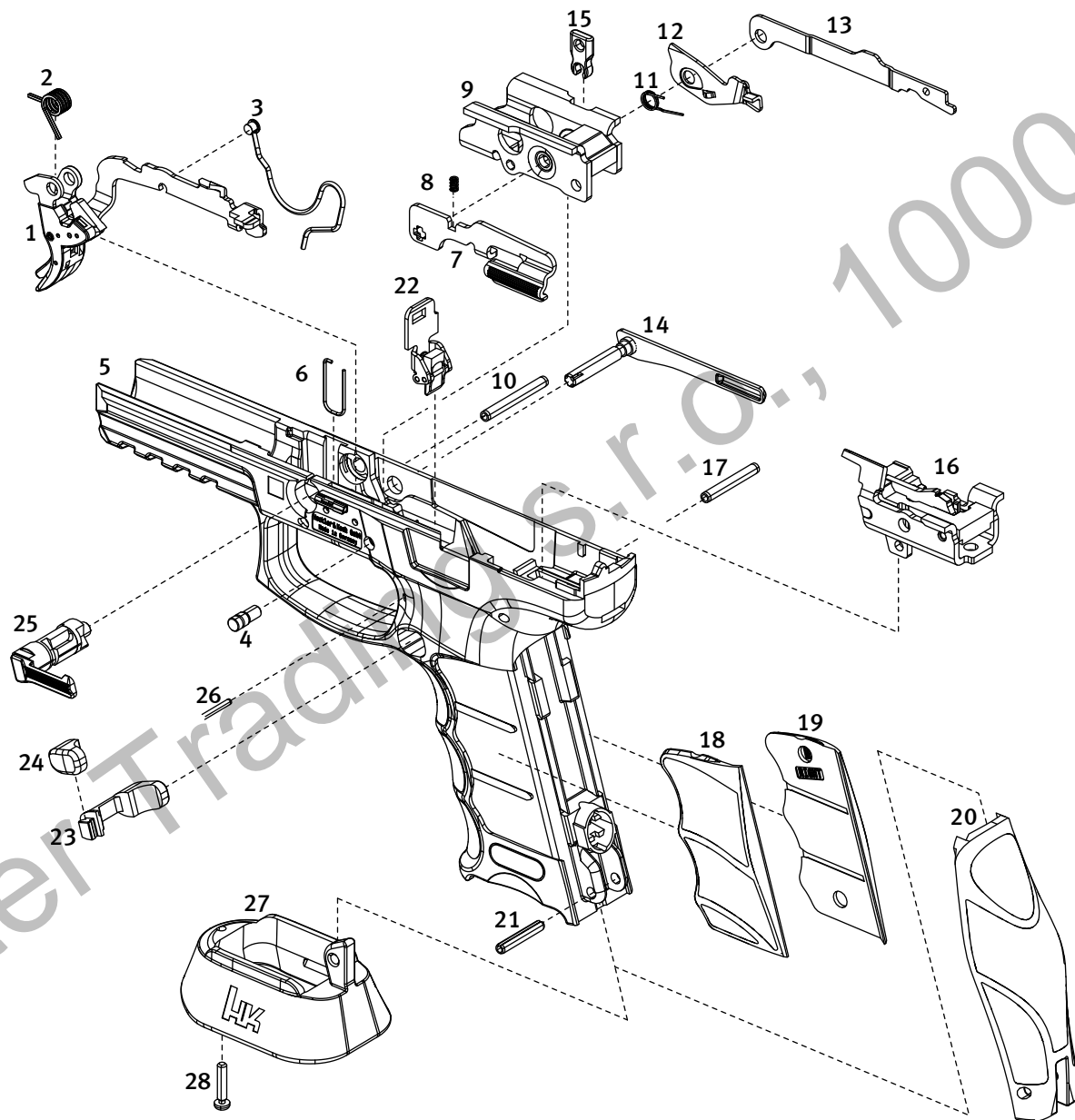

FRAME, COMPL.



SFP9 OR PB MATCH 19 mm x 19 Calibre

ITEM	DESIGNATION	ID	NSN	SP 100		COMMENTS
>>	Push-Button M, compl. (Pos. 23 - 24)	250865		5		
23	Slide	250866		3		
24	Push-Button M	250874		10		
25	Disassembly lever	260427		5		
26	Clamping sleeve	968761		10		
27	Jet funnel	254158		3		
28	Screw for jet funnel	947175		10		

Walter Trading S.r.o., 10004749

Walter Trading S.r.l. 10004749

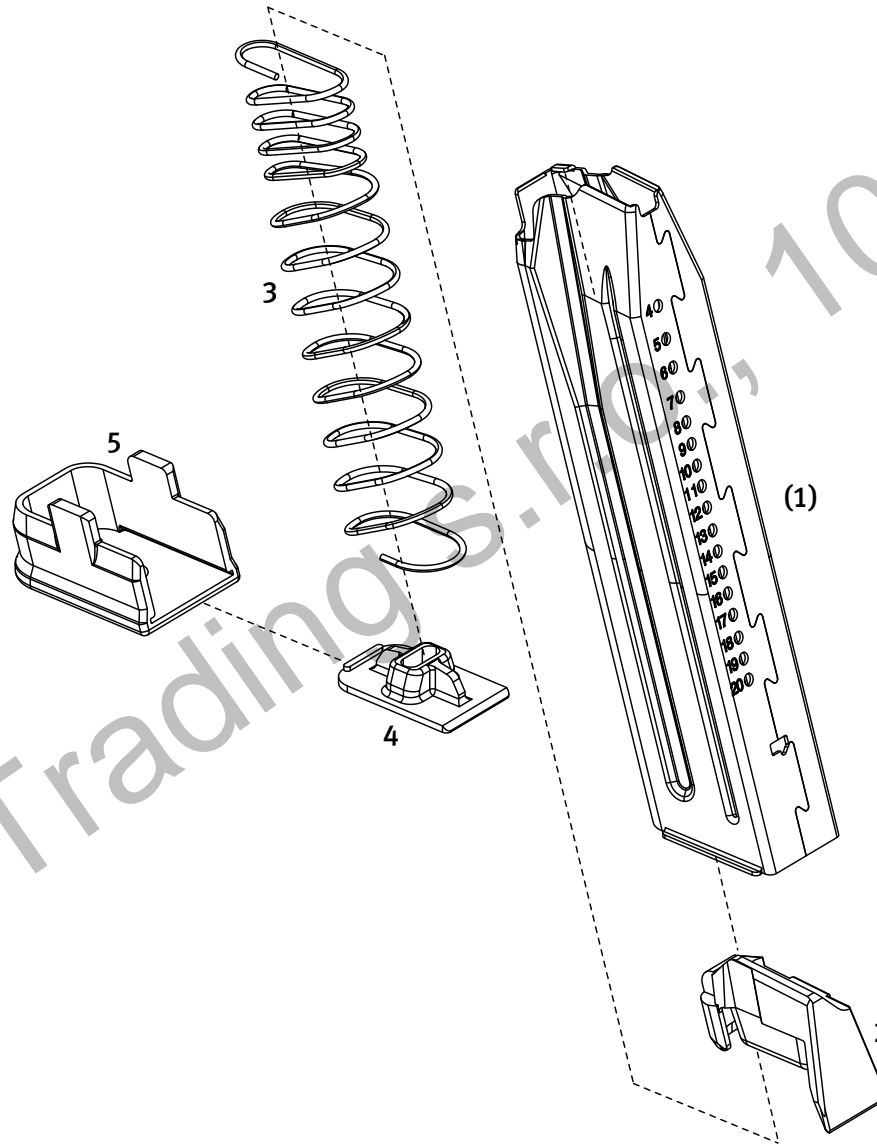

MAGAZINE, COMPL.



SFP9 OR PB MATCH 19 mm x 19 Calibre

ITEM	DESIGNATION	ID	NSN	SP 100		COMMENTS
>	Magazine, compl. (Item 1 - 5)	254298		10		
1	Magazine housing	--		--		only as magazine, compl. available
2	Follower	215836		--		
3	Magazine spring	239851		--		
4	Magazine locking plate	215844		--		
5	Magazine floor plate	254278		--		

Walter Trading S.r.O., 10004749



Walter Trac... r.o., 10004749

CLEANING KIT



SFP9 OR PB MATCH 19 mm x 19 Calibre

ITEM	DESIGNATION	ID	NSN	SP 100	COMMENTS
>	Cleaning kit, compl. (Item 1 - 8)	988426		10	
1	Container for cleaning kit	979833		--	
>>	Cleaning rod, compl. (Item 2 - 3)	967011		--	
2	Screw handle rod	--		--	
3	Extension rod	--		--	
4	Pull-through holder	967010		--	
5	Wool pull-through	299511		--	
6	Oil brush	967009		--	
7	Barrel cleaning brush	967008		--	
8	Oil bottle	924026		--	

Walter Trading S.r.l., 10004749

Walter Trading S.r.l., 10004749

Walter Trading S.r.l., 10004749



HK TECHNISCHE
DOKUMENTATION

Heckler & Koch GmbH
Heckler & Koch-Str. 1
78727 Oberndorf/N., Germany

+49 (0) 74 23 / 79-0
+49 (0) 74 23 / 79-23 50

✉ TD@heckler-koch-de.com
🌐 www.heckler-koch.com

This document is subject to the know-how protection instruction. The distribution of this document is subject to approval. The transfer to unauthorized third parties is prohibited.